

MASTER LEDspot LV

MAS LEDspotLV D 7-35W 927 MR16 36D



Delivering a warm, halogen-like accent beam, MASTER LEDspot LV is an ideal retrofit solution for spot and general lighting applications in the hospitality industry. It is particularly suited to public areas such as receptions, lobbies, corridors, stairwells and washrooms, where the light is on all the time. The robustly designed MASTER LEDspot offers a choice of beam angles for a clearly defined beam spread. There is no UV or IR in the beam, making it suitable for illuminating heat-sensitive objects (food, organic materials, paintings, etc.). The patented intelligent driver enables broad compatibility with existing electromagnetic and electronic halogen transformers. The dimmable versions drive further efficiencies, while helping to create the desired atmosphere.

Product data

• General Information

Cap-Base	GU5.3
Bulb Shape	MR16 [2inch/50mm]
Nominal Lifetime (Nom)	40000 h
Switching Cycle	50000X
B50L70	40000
Technical Type	7-35W

• Light Technical

Color Code	927
Beam Angle (Nom)	36 °
Light Distribution	Medium beam 36°
Luminous Flux (Nom)	420 lm
Luminous Flux (Rated) (Nom)	420 lm
Luminous Intensity (Nom)	1150 cd
Color Designation	Warm White (WW)
Rated Beam Angle	36 °
Correlated Color Temperature (Nom)	2700 K
Luminous Efficacy (rated) (Nom)	57.14 lm/W
Color Consistency	6 steps
Color Rendering Index (Nom)	90
LLMF At End Of Nominal Lifetime (Nom)	70 %

Luminous Flux In 90° Cone (Rated)	400 lm
-----------------------------------	--------

• Operating and Electrical

Power (Rated) (Nom)	7 W
Lamp Current (Nom)	720 mA
Wattage Equivalent	35 W
Starting Time (Max)	0.5 s
Warm Up Time To 60% Light (Nom)	1 s
Power Factor (Nom)	0.7
Voltage (Nom)	12 V

• Temperature

T-Case Maximum (Nom)	92 °C
----------------------	-------

• Controls and Dimming

Dimmable	Yes
----------	-----

• Approval and Application

Energy Saving Product	Yes
Suitable For Accent Lighting	Yes
Energy Efficiency Label (EEL)	A

PHILIPS

MASTER LEDspot LV

Energy Consumption 8 kWh
kWh/1000 h

• Product Data

Full product code 871869665925000
Order product name MAS LEDspotLV D 7-35W 927 MR16 36D

EAN/UPC - Product 8718696659250
Order code 929001153132
Numerator - Quantity Per Pack 1
Numerator - Packs per outer box 10
Material Nr. (12NC) 929001153132
Net Weight (Piece) 0.045 kg

Warnings and Safety

- Operating temperature range is between -20° C and 45° C ambient

- Only to apply in dry or damp locations and most of open fixtures with lamp-holders that offer sufficient space (10 mm free air space)
- Not intended for use with emergency light fixtures or exit lights

Dimensional drawing

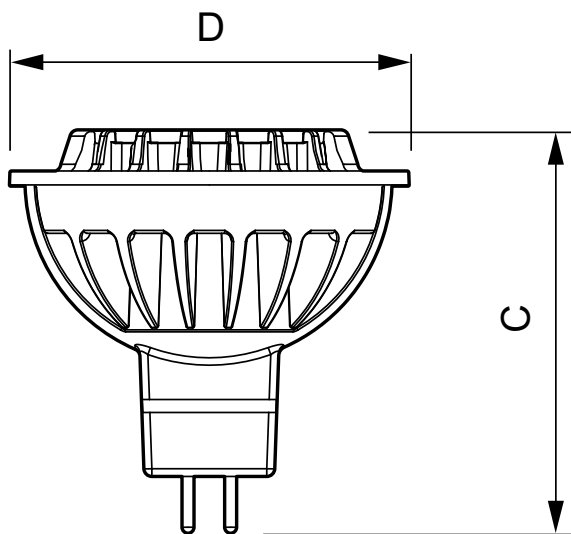

7-35 W GU5.3 MR16

LED D 7-35W 827 MR16 36D

Product	D	C
MAS LEDspotLV D 7-35W 927 MR16 36D	50.5 mm	50.5 mm

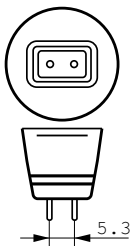

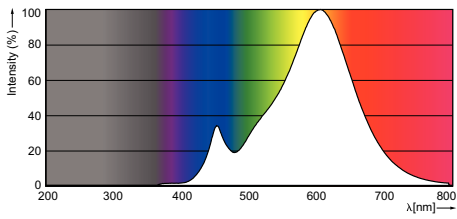
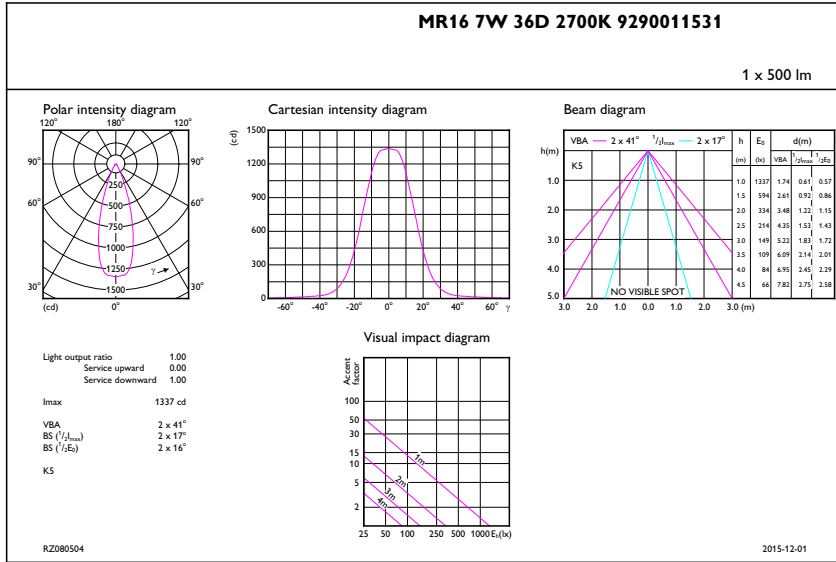

© 2016 Philips Lighting Holding B.V.
 All rights reserved.

Specifications are subject to change without notice. Trademarks are the property of Koninklijke Philips N.V. (Royal Philips) or their respective owners.

www.philips.com/lighting

2016, September 16
 data subject to change